

Glenwood™ Sheldon™

POCKET BILLIARD TABLE INSTALLATION MANUAL



www.brunswickbilliards.com
SERVICE DEPARTMENT P.O. BOX 68 BRISTOL, WI 53104
Email: Brunswickservice@brunswickbilliards.com

NOTE: Please use the instructions in this manual to assemble the tables.
Illustrations may be different depending on the table being assembled.
Also note that careful handling of *all* components
will assure damage-free assembly.



FIGURE ONE

Step #1: Position the side sills with the inside up on a flat protected surface. Loosely attach the dovetail cleats to each side sill using 5/16-18 x 1-1/4" hex head cap screws and 5/16 washers.

Step #2: Assure that the cleats are perpendicular to the top of the sill and securely tightened.

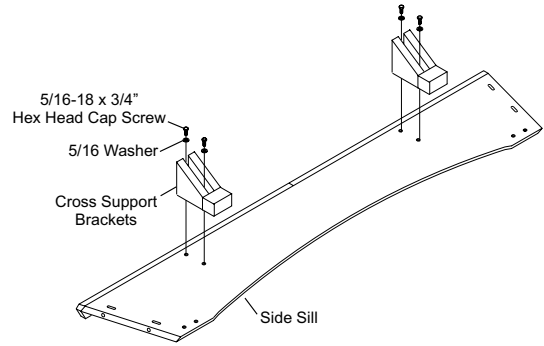

FIGURE ONE

FIGURE TWO

Step #3: Loosely attach the corner brackets to the ends of the side sills using 5/16-18 x 1-3/4" hex head cap screws, 5/16 washers and 5/16-18 tab weld nuts.

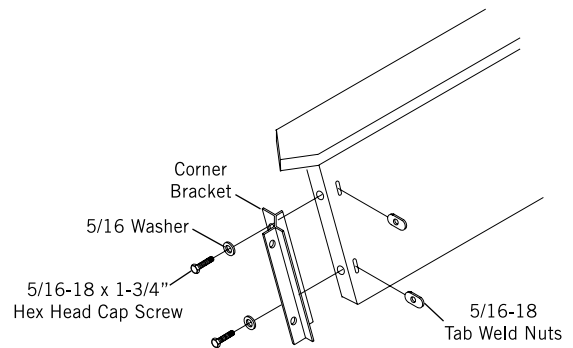

FIGURE TWO

FIGURE THREE

Step #4: Position the baseframe end sills to the side sills, and loosely attach the brackets already attached to the side sills with the same hardware.

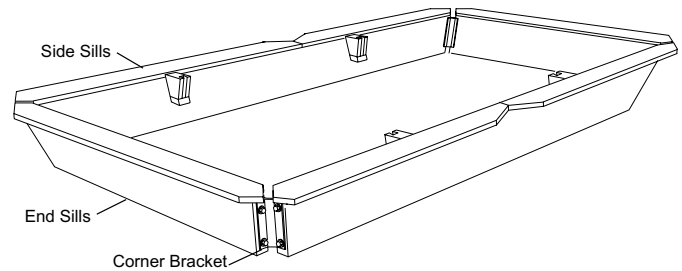

FIGURE THREE

LEG AND BASEFRAME ASSEMBLY (CONTINUED)

•GLENWOOD•SHELDON

FIGURE FOUR

Step #5: Loosely attach the leg attach brackets to the baseframe using 5/16-18 x 3/4" hex head cap screws and 5/16 washers.

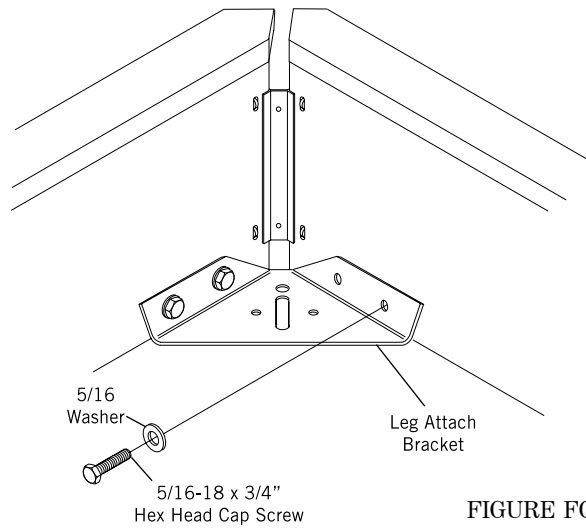

FIGURE FOUR

FIGURES FIVE AND SIX

Step #6: With the aide of another person, carefully place the baseframe on top of the legs and loosely attach using 5/16-18 x 1" hex head cap screws and 5/16" washers.

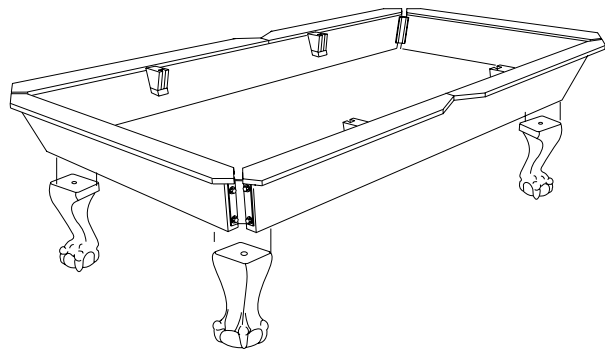

FIGURE FIVE

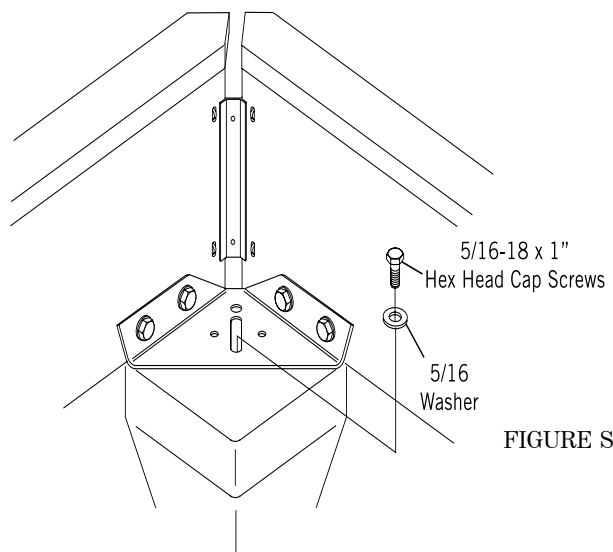

FIGURE SIX



LEG AND BASEFRAME ASSEMBLY (OPTIONAL LEG PLATE)

• GLENWOOD • SHELDON

FIGURE SEVEN (OPTIONAL)

Step #7: Install leg plate on top of leg, cavity side down. Be sure slot is aligned from front to back of corner of leg.

Step #8: Position leg plate with plate underneath sills.

Step #9: Install 3/4" hex head cap screw (included in leg plate carton) and washer from hardware kit, through the slot in the metal leg attach bracket, through the slot in the leg plate and into the threaded insert in leg. Slot in plate must align with slot in leg attach bracket. Hand tighten only at this time.

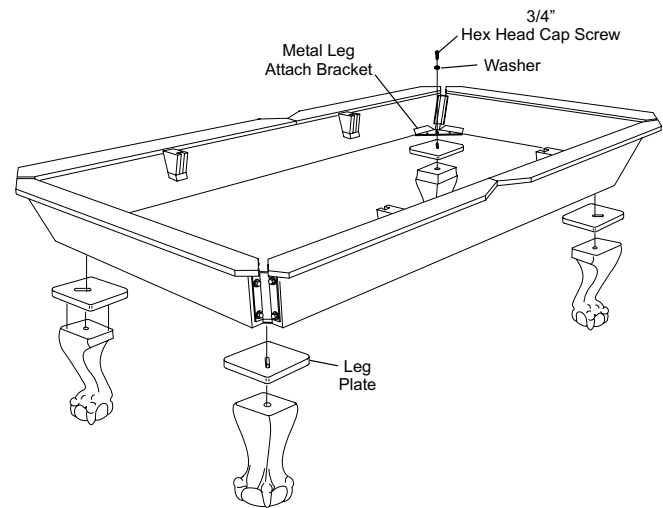

FIGURE SEVEN

FIGURE EIGHT (OPTIONAL)

Step #10: Align leg plate square to sills with approximately 1/8" reveal between corner molding and detail shoulder of leg plate.

Step #11: Position leg in center of cavity with approximately equal gap on all four sides of leg. Fully tighten leg screw making sure leg does not rotate out of position during tightening.

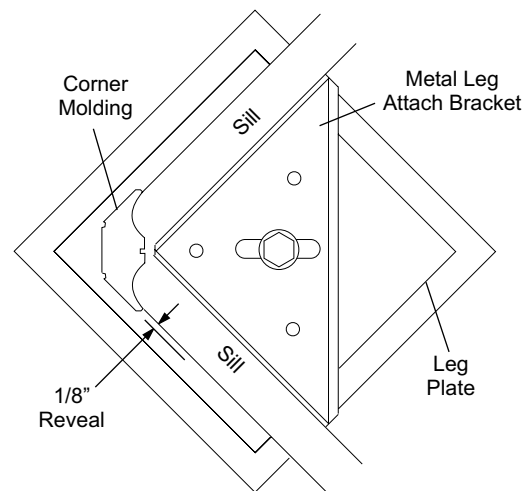

FIGURE EIGHT



LEG AND BASEFRAME ASSEMBLY CONTINUED

•GLENWOOD• SHELDON

FIGURE NINE

Step #12: Slide cross supports down into dovetail cleats.

Step #8: Square the table using a carpenter's square and assure that the baseframe is sitting flush on the leg top and securely tighten all corner brackets. Firmly push downward on the baseframe and securely tighten the leg attach brackets.

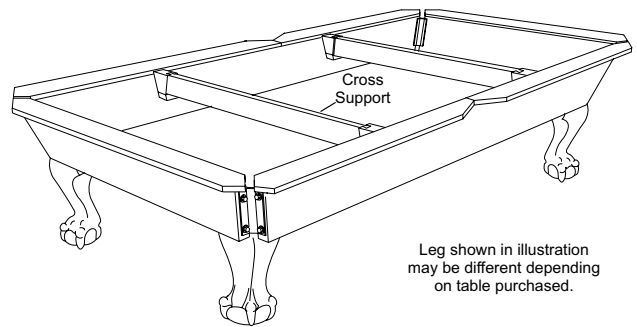

Leg shown in illustration may be different depending on table purchased.

FIGURE NINE

FIGURE TEN

Step #13: Position the corner post over the baseframe. While using the two holes in the center of the corner bracket, pilot drill 1/8" diameter holes into the corner post. (Be careful not to drill all the way through.) Hold the corner post firmly in position and attach using #8 x 1-1/4" round head screws and #8 washers.

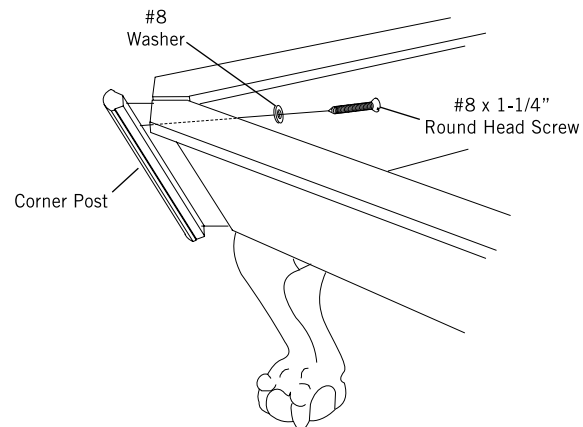

FIGURE TEN

FIGURE ELEVEN

Step #14: At each corner, adjust the legs to the desired location and securely tighten the center bolt to the leg. While using the three remaining holes in each leg attach bracket as a template, pilot drill 1/8" diameter holes into the legs approximately 1-1/2" deep. Complete the attachment of the leg bracket using #10 x 1-1/2" hex washer head self-tapping screws.

Step #15: Position the table in its permanent location. We recommend a 60" clearance around perimeter of the table. Proceed with leveling and slate installation.

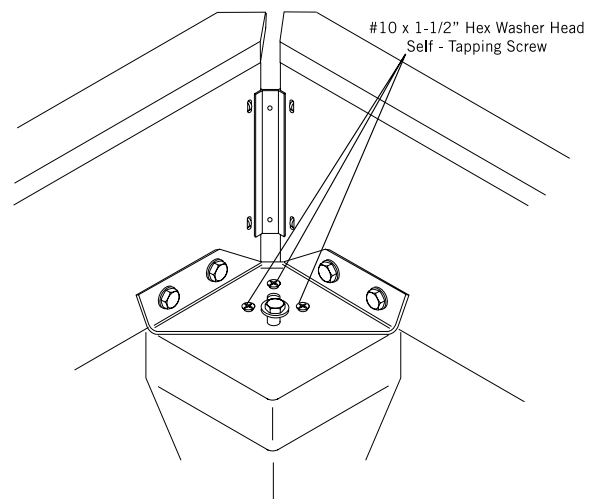

FIGURE ELEVEN



IMPORTANT: Prior to installing the slate, it is important to level the baseframe.

FIGURE ONE

Step #1: With a carpenter's level, locate the highest corner of the baseframe. Level the baseframe by positioning shims (supplied with the table) underneath the other three legs as necessary.

Step #2: Be sure that the top surfaces are absolutely flush. Add shims under the legs as necessary to accomplish this.

Step #3: With the baseframe level and carefully positioned in its permanent location, place the center section of slate on the table. Be sure that the center section is precisely square with the frame and an equal amount of overhang exists on both sides of the table.

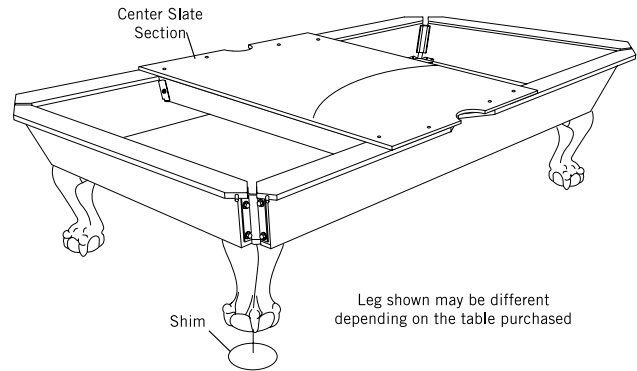

FIGURE ONE

FIGURE TWO

Step #4: Position the two end slate sections on the baseframe. Be sure that the penciled arc forms a radius.

Step #5: Recheck to be sure that the slate has an equal amount of overhang around the baseframe.

Step #6: Using the twelve (12) countersunk holes in the slate as a template, pilot drill 5/32" diameter holes into slate attach plate.

Step #7: Securely fasten the end slate section at both ends of the table.

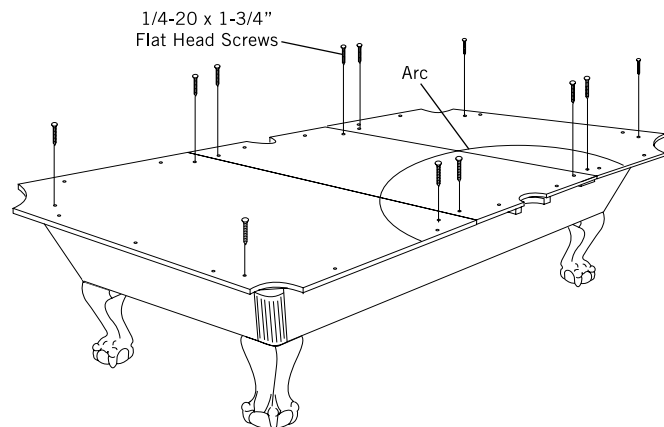

FIGURE TWO



SLATE ASSEMBLY AND LEVELING (CONTINUED)

•GLENWOOD•SHELDON

FIGURE THREE

Step #8: With a precision level, level each end slate section by driving wooden slate wedges (provided) between the top of the baseframe and bottom of the slate. Keep the wedges as close to the countersunk holes as possible. (Loosen and tighten screw as required.)

Step #9: With both end slates perfectly level, continue fastening the end slates at the joints. Recheck for levelness and if necessary, back the screws out and adjust the shim position, then retighten the slate attaching screws.

Step #10: When satisfied that both end slates are level, shim the center slate section as required to obtain a flush fit at both joints, then screw the center slate down.

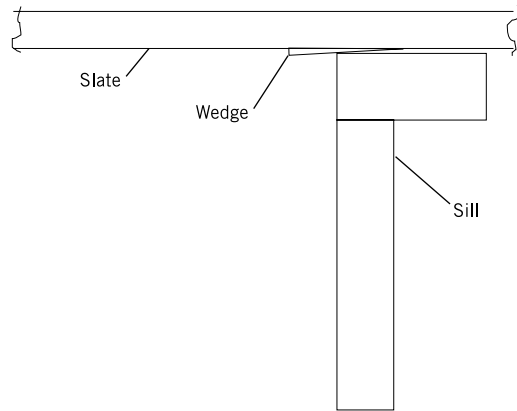

FIGURE THREE

FIGURE FOUR

Step #11: Slate joints can now be filled with fast setting rock hard putty, bee's wax or slate joint wax. Lightly sand or scrape across joint after grouting.

Step #12: From the end of a bed cloth, cut strips of cloth approximately 1-1/2" wide by approximately 8" long and glue the strips to the pocket cutouts (3m Super 77 is recommended for this step). This is important as this will provide cushioning from ball impact and the bed cloth will last much longer.

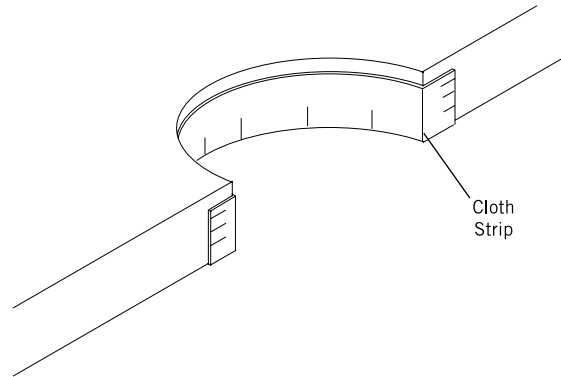

FIGURE FOUR



Before attaching bed cloth clean slate thoroughly:

FIGURE ONE

Step #1: Lay the bed cloth over the top of the slate, nap side up. Leave an equal amount of cloth overhang at the end and sides of the slate.

NOTE: *In determining the direction of the nap, run your hand lightly over the surface of the cloth. If it meets resistance, it is going against the nap.*

Step #2: Adjust cloth to leave only enough cloth overhang at the head end and left side to permit tacking into the wood slate frame. Leave the balance of cloth overhang at the foot end and right side.

NOTE: *Do not spread tacks or staples on the bed cloth because it could cut the cloth. Keep them in a container that slides over the cloth.*

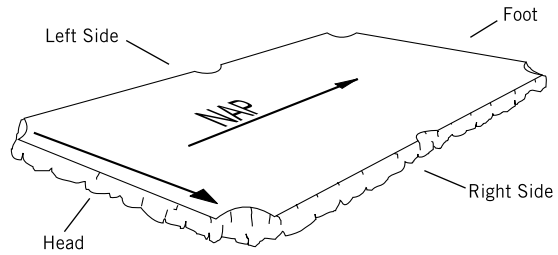

FIGURE ONE

FIGURE TWO

Step #3: Tack or staple the cloth securely to the wood frame at location #1 with two tacks or staples approximately 2" apart.

Step #4: Stretch the cloth across the table and tack or staple securely at location #2 with two tacks or staples 2" apart.

Step #5: Stretch the cloth from location #1 to location #3 and tack or staple securely into the wood frame at the left side of the table.

Step #6: Stretching the cloth across the table from location #3 and pulling from location #2, tack or staple the cloth at location #4.

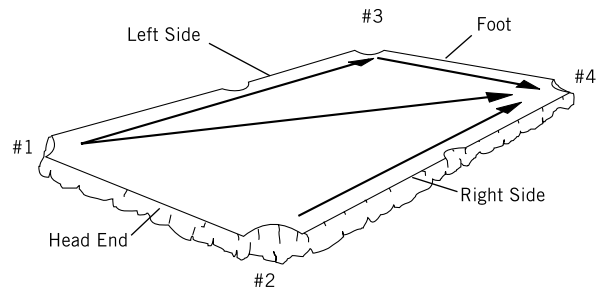

FIGURE TWO

FIGURE THREE

Step #7: On the left side, stretch the cloth tightly from location #1 toward the side pocket opening and tack or staple securely at location #5.

Step #8: Repeat Step 5, stretching the cloth from location #3 and tacking or stapling at location #6.

Step #9: On the right side of the table, grasp the cloth firmly and stretch across the table from location #5 and toward the side pocket from location #2 and tack or staple at location #7.

Step #10: Repeat Step 9, stretching from location #6 and toward the side pocket from location #4 and tack or staple at location #8.

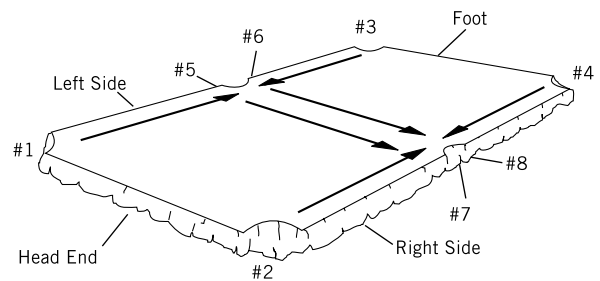

FIGURE THREE

ATTACHING BED CLOTH (CONTINUED)

FIGURE FOUR

Step #11: At location #9, cut a short slit in the cloth at the edge centered on the side pocket opening. Grasp the cloth firmly above this slit, pull the cloth into the side pocket opening and tack or staple to the wood frame. Complete fastening of the cloth to the side pocket opening, making sure the cloth is tacked or stapled to the wood frame.

Step #12: Stretching the cloth tightly across the table from location #9, repeat Step 11 at location #10.

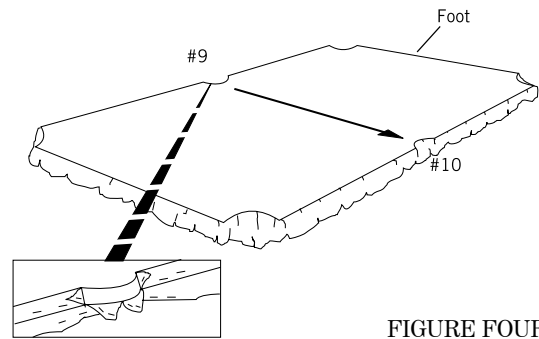

FIGURE FOUR

FIGURE FIVE

Step #13: At the head end of the table, tack or staple the cloth at location #11, maintaining uniform overhang.

Step #14: Pull the cloth from location #11 toward location #12 and tack or staple securely along the wood frame, keeping the cloth even along the head end.

Step #15: Stretch the cloth firmly from location #11 to the foot end of the table and tack or staple at location #13.

Step #16: Stretch the cloth tightly from locations #12 and #13 toward location #14 and tack or staple securely along the wood slate frame.

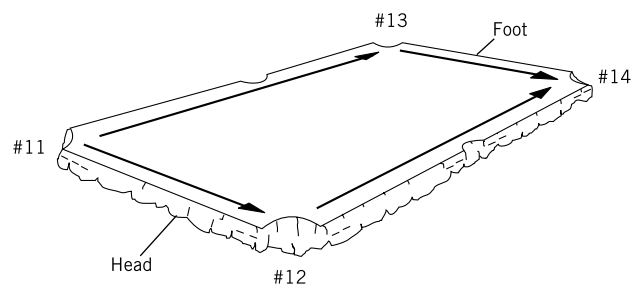

FIGURE FIVE

FIGURE SIX

Step #17: Tack or staple all of the left side on 2" centers keeping the cloth even along the wood frame.

Step #18: Tack or staple the balance of the head end on 2" centers also keeping the cloth even along the wood frame.

Step #19: Stretch the cloth tightly toward the foot end of the table, tacking or stapling on 2" centers along the wood frame at the foot end.

Step #20: Stretch the cloth tightly across the table to the right side, tacking or stapling on 2" centers all the way along the wood frame at the right side.

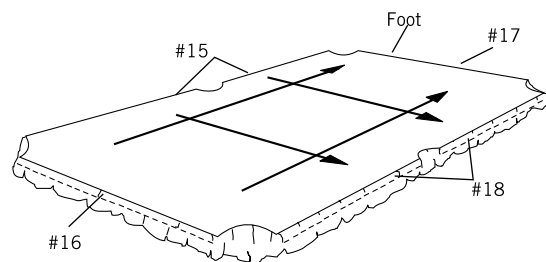

FIGURE SIX

FIGURE SEVEN

Step #21: Stretch the cloth into the corner pocket openings and tack or staple to the wood slate frame.

Step #22: Trim off excess cloth around the perimeter of the slate. Locate the eighteen (18) rail attach holes and cut clearance holes in the cloth with a sharp knife.

NOTE: Occasionally cloth will stretch, leaving wrinkles at the pockets. To retighten, remove apron, one end rail and one side rail. Pull cloth taut, and retack or restaple along the open end and side to restore original tightness.

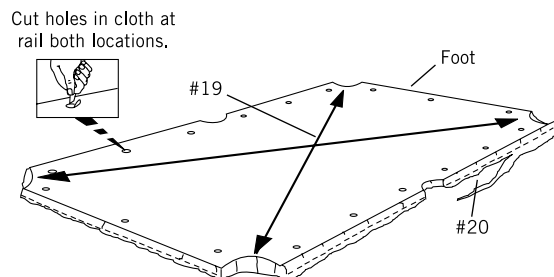

FIGURE SEVEN



FIGURE ONE

Step #1: Position rails upside down on a protected surface in their respective locations.

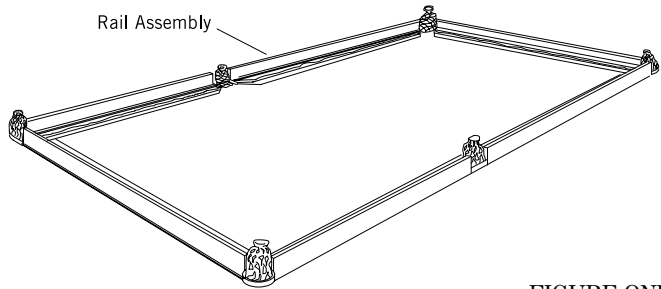

FIGURE ONE

FIGURE TWO

Step #2: Insert stud of pocket iron into the end of the rail as shown. Press in tightly against the end on the rail while threading a 5/16-18 x 1" hex head bolt with washer into the threaded hole in the stud. Tighten securely.

Step #3: Repeat above procedure with the remaining five pockets.

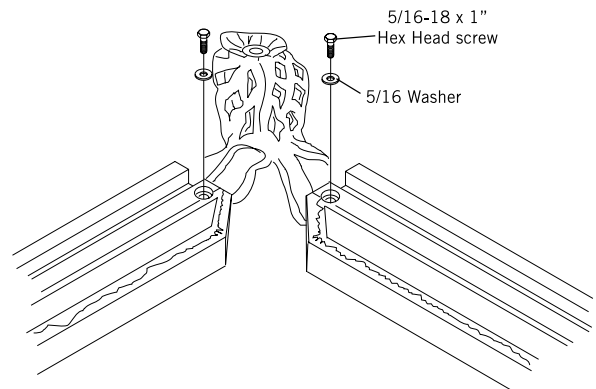

FIGURE TWO

FIGURE THREE

Step #4: Thread a machine stud into the three locations of each rail as shown.

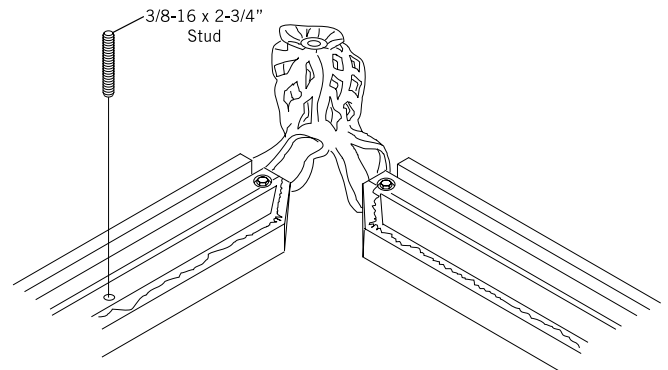

FIGURE THREE

FIGURE ONE

Step #1: With rail assembly remaining upside down, position the apron brackets into the groove with the short leg of the bracket facing the back of the rail, approximately 3 - 4" from each end of the rail. With the brackets firmly seated, attach them to the back of the rail core with #6 x 3/4" flat head screws through hole line "B".

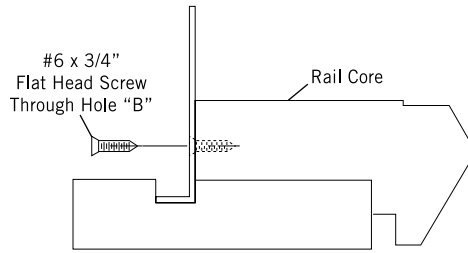

FIGURE ONE

FIGURE TWO

Step #2: Position the aprons into the grooves so the ends of apron and rails are even. Apply downward pressure on the apron and attach the brackets to the back of the apron with #8 x 1/2" pan head screws through hole line "A".

Step #3: Using a partner, carefully turn the rail and pocket assembly over and lower over the table.

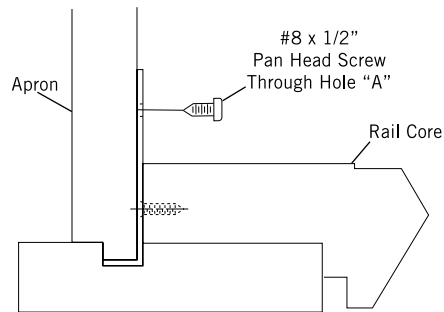

FIGURE TWO

FIGURE THREE

Step #4: Align the eighteen machine studs with the eighteen clearance through the slate and lower the assembly onto the slate.

Step #5: Thread the 3/8-16 hex nut and dome washer onto the machine stud (three places) at the ends of the table and tighten securely.

Step #6: Making sure that the side rails are in a straight line as sighted down the length of the table (cushion side), fasten the side rails securely with remaining nuts and dome washers.

Step #7: Attach pocket tabs to underside of slate frame pad with nails, or 1/2" staples.

Step #8: Thoroughly brush the area on which the bed spots are to be applied. Position the bed spot and firmly roll a ball over the spot to achieve good adhesion.

NOTE: Bed spots are self adhesive.

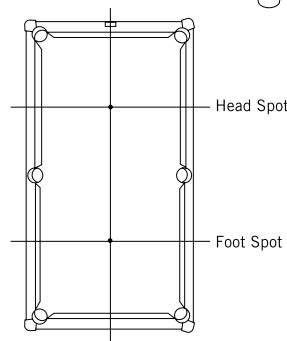
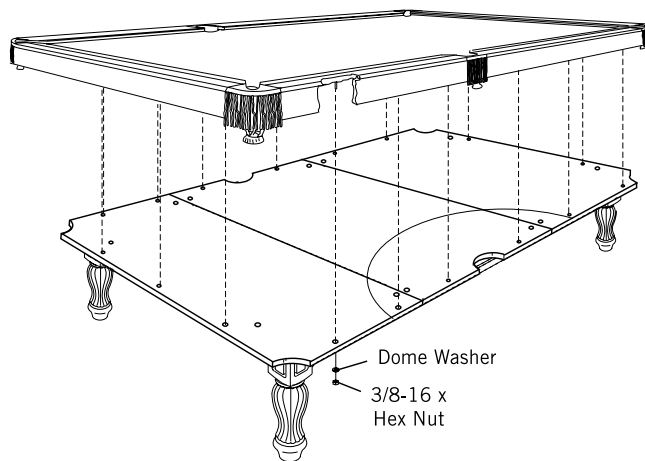

FIGURE THREE

